



The power of international collaboration

Everything you need to know

Join our Global Village at the Swiss Biotech Day to connect your biotech cluster with the Swiss biotech ecosystem for lasting business ties.

Presented by:



Supported by:



Global Village **Connecting global biotech executives to Swiss innovators**

The Global Village, spearheaded by the Swiss Biotech Association, serves as a premier platform for fostering international collaboration and networking within the biotech and life sciences industries. In partnership with leading Swiss organizations, it offers a continuous, year-round gateway for global biotech clusters to forge and deepen strategic, long-term partnerships within Switzerland's thriving biotech ecosystem.



The Global Village Mission

Connecting global life sciences hubs with Swiss biotech leaders

Facilitates strategic connections between international and Swiss biotech executives and decision makers.

Empowering international delegations

Provides dedicated offerings for national and regional delegations from international life sciences clusters who wish to develop and strengthen long-term and sustainable business ties and collaborations with key decision-makers in the Swiss biotech ecosystem.

Driving collaborative excellence

Promotes the exchange of best practices and supports the development of actionable plans and joint initiatives that deliver mutual value and benefit all stakeholders involved.

While the Swiss Biotech Day serves as the anchor event for the Global Village, it extends far beyond. Facilitating ongoing collaboration, the Global Village allows industry stakeholders and decision-makers to build meaningful connections with Swiss innovation. This continuous engagement ensures a dynamic exchange of ideas, resources, and opportunities, driving sustained progress and impactful partnerships.

The Global Village platform provides a spectrum of engagement opportunities – from gaining insights into the diversity of the Swiss biotech landscape to facilitating partnerships and long-term collaborations.

Since its inception in 2022, the Global Village has attracted delegations from across North and South America, Asia, Australia, and Europe, reflecting its success in advancing global biotech collaboration.

Join the Global Village and become part of a dynamic network shaping the future of global biotech collaboration



- Connect with Swiss biotech entrepreneurs, CEOs and investors
- Explore and initiate collaboration with Swiss biotech leaders
- Drive cross-border investments
- Build public/private partnerships
- Enhance academic and R&D cooperation
- Promote talent exchange
- Influence policy development on shared priorities

If you are interested to participate in the Global Village contact us at globalvillage@swissbiotech.org or visit our [website](#)

The benefits for international delegations

Enhanced visibility and outreach

Gain significant exposure and outreach opportunities through your country or regional delegation booth, the partnering platform and on-site engagements. In 2024, the Swiss Biotech Day attracted around 2,500 participants from more than 40 countries.

Exclusive engagement opportunities

Participate in the Global Village's dedicated program, featuring activities such as an opening ceremony, international reception, marketplace networking, and side visits, all designed to foster meaningful connections alongside the Swiss Biotech Day.

Sustainable long-term partnerships

Engage in follow-up activities before and after the Swiss Biotech Day to develop sustainable, long-term engagements. These include meetings at international BIO conferences or through ad hoc follow-up discussions.

How to participate in the Global Village

The Global Village is open to national and regional biotech and life sciences clusters. Each delegation should designate a lead and co-lead to serve as primary contacts and to coordinate the delegation's activities.

Coordinate delegation

Identify delegation members, facilitate their participation, and manage delegation activities.

Manage budget

Secure the necessary budget to cover participation and attendance costs.

Prepare for engagement

Coordinate the creation of promotional material for the delegation booth and ensure the delegation is well prepared to participate in all offered activities.

Coordinate meetings

If requested by the delegation, arrange individual meetings before/after the Swiss Biotech Day.

Plan long-term engagement

Develop an action plan for follow-up activities after your presence at the Swiss Biotech Day.

Other ways to participate in the Global Village

Interested foreign parties wishing to join a delegation are encouraged to contact us and express their interest.

Similarly, Swiss companies connected to leading international ecosystems are invited to signal their interest in contributing to the Global Village initiative.

How to compose an effective delegation

Selecting delegation members with existing ties or a strong interest in Switzerland and its biotech ecosystem is crucial for success.

To maximize participation and impact in the Global Village, delegations should include key decision makers such as:

- C-level biotech leaders
- Biotech investors and venture builders
- Leading translational centers (e.g. university hospitals, clinical investigators)
- Universities and private research centers
- Incubators, accelerators, ecosystem facilitators and talent developers
- Government bodies with a vested interest (e.g. regulatory agencies)



Your Global Village booth at the Swiss Biotech Day

The size of the Global Village delegation determines the choice of available exhibition space and ticket numbers. Delegation members benefit from full access to the Swiss Biotech Day conference and partnering platform, along with exclusive access to the Global Village program (see next page).

BASIC BOOTH – 9 square meters

- Delegation with **up to 6 participants**
- Booth with exhibition space 3 x 3m in the Global Village area
- 3 high tables, 6 bar chairs, 1 table, 2 chairs
- 3 partnering meeting locations
- A printed back wall (W: 3m x H: 2.3m)

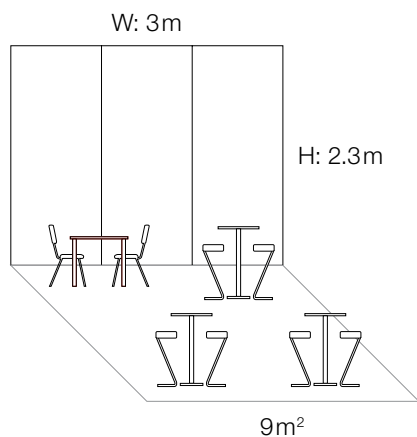

- Publication of a country/region profile on the event website
- Max. 3 logos on selected Global Village material
- 3 full conference tickets incl. partnering platform
- International reception for networking with other delegations
- Up to 3 additional conference tickets at a discount (CHF 500 each)

CHF 5,500 plus VAT

The exact booth measurements will be provided upon booking.

ENHANCED VISIBILITY BOOTH – 25 square meters

- Delegation with **more than 6 participants**
- Booth with exhibition space 5 x 5m in the Global Village area
- 6 high tables, 12 bar chairs, 1 table, 2 chairs
- 6 partnering meeting locations
- A printed back wall (W: 5m x H: 2.3m)

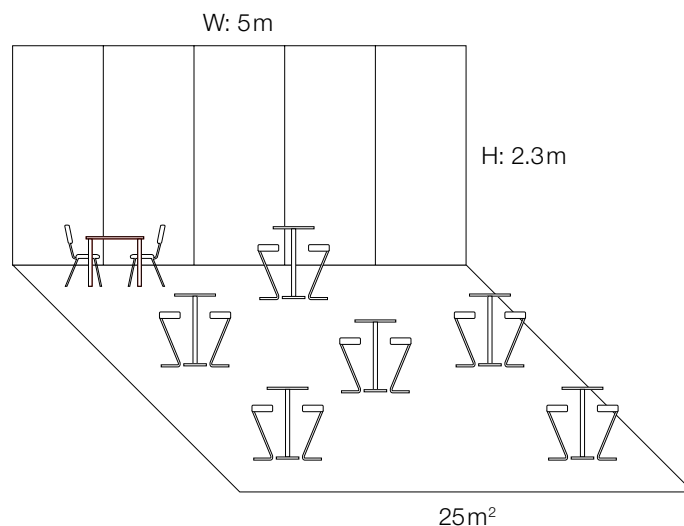

- Publication of a country/region profile on the event website
- Max. 3 logos on selected Global Village material
- 5 full conference tickets incl. partnering platform
- International reception for networking with other delegations
- Additional full conference tickets at a discount (CHF 500)

CHF 9,000 plus VAT

The exact booth measurements will be provided upon booking.



The exclusive program to connect with Swiss biotechs

To enhance networking and collaboration with the Swiss biotech community, the Global Village offers a dedicated program with several engagement opportunities.

We encourage active participation in these offers, which will require your input to tailor content, themes and topics to your preferences.

Timely engagement

This is crucial to align your suggestions with the Swiss biotech perspective and support your overall engagement efforts. Please review the timeline on the next page to ensure effective coordination.

Your engagement opportunities

Opening ceremony

- Welcome and introduction by the Swiss Biotech Association
- Overview of 2025 program, past editions and success stories

International reception and marketplace

- Networking reception
- Brainstorming marketplace featuring moderated discussions on common interests
- Photo booth and video interviews
- Farewell speech by the Swiss Biotech Association announcing the “Country partnership of the year”

Side visits to Swiss biotech hotspots

Visit leading biotech locations across Switzerland, including R&D biotech companies, universities, investors and pharma companies before or after the Swiss Biotech Day.

Tailor-made visits can be arranged upon advance request, subject to availability of Swiss partners and with organizational engagement of delegation.

Your active participation and timely coordination will be key to maximizing the benefits of the Global Village program.

Organization and timelines



2024

Mid-December

Confirm your participation **with additional engagement opportunities**

2025

End January

Fine-tune your additional engagement opportunities

March

Partnering opens

End March

Confirm your participation **without additional engagement opportunities**

April

Deadline for printed materials

Mid April

Register for your side visits

To achieve impactful collaboration and fully leverage all available opportunities, we require your active preparation and engagement. Utilizing existing tools, such as the **Swiss Biotech Directory** to search and identify companies of interest and/or potential partners, and adhering to the timelines will streamline the preparation process and enhance your overall experience.

If you are interested to participate in the Global Village contact us at globalvillage@swissbiotech.org or visit our [website](#)

SWISS BIOTECH DAY 2025

© Swiss Biotech Association

May 5–6, 2025
Congress Center Basel

What you can expect:

- › Meet 2,500+ senior experts from the life science industry
- › 100+ exhibitors and Global Village with international delegations from all over the world
- › Swiss Biotech Success Stories Awards
- › Innovative biotech start-ups and medium-sized biotech companies
- › Thematic company pitching sessions
- › Thematically focused panel discussions
- › Swiss Biotech Report 2024
- › Pre-scheduled one-to-one partnering meetings
- › General Assembly of the Swiss Biotech Association



Sign in on our website at swissbiotechday.ch and stay updated about any news.

Host:



Organizing & marketing partner:

bamconn